

Digitized Automation for a Changing World

Delta Planetary Gearbox PS High Precision Series PA Precision Series

Planetary Gearbox PS High Precision S

The Planetary Gearbox PS Series features many benefits such as low noise, high smoothly transfer power from motor to applications and to apply to a variety of industrial machine tools, industrial robots, medical inspection devices, high-precision testing

Helical Gear Design

The PS Series employs helical gears that provide higher gear mesh frequency than regular spur gears and features smooth performance, low noise, high torque output and low backlash.



Synthetic Lubrication

The Protective class IP65 sealed design avoids leakage problems and requires no maintenance during the product's lifetime.



Integrated Planetary Arm Bracket and Dual-cantilever Design

The planetary arm bracket and the output shaft are constructed in one piece to increase torsional rigidity and accuracy. The entire structure is one-time machined for high controlling accuracy in a specified tolerance.



One-piece Gearbox with Advanced Surface Treatment

The gearbox and internal gear ring are constructed in one piece and certified with the DIN6 class standard. The surface of the gearbox is processed with anti-corrosive coating to enhance environment resistance and corrosion resistance capabilities.

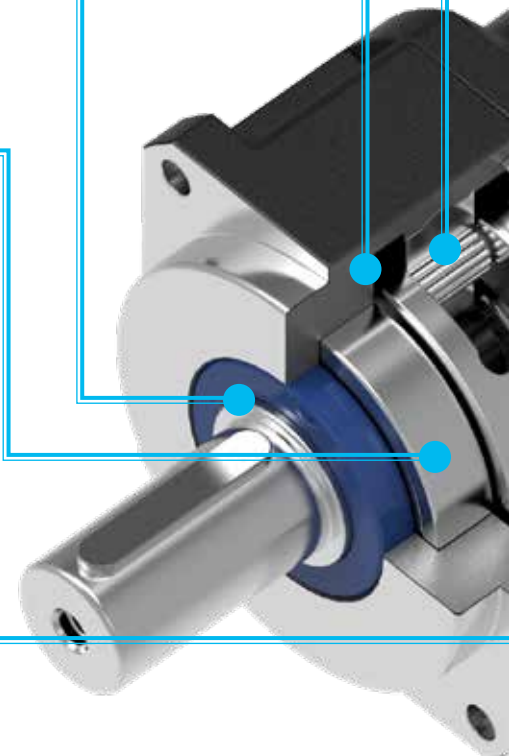

Series

output torque and low backlash. It is able to industries, including aerospace, semi-conductors, equipment and other automated industry fields.



Full Needle Roller Bearings Design

The planetary gear transmission is designed with full needle roller bearings without retainer to increase the contact surface for enhancing structural rigidity and service life.



High Precision Gear Machining

The planetary gear and sun gear are made of high quality Ni-Cr-Mo alloy steel (SNM220). With high-precision machining including cutting, carburizing to hardness of 57-60 HRC and surface-grinding, the gear provides better wear resistance, impact resistance and longer service life than nitridedand gears (Accuracy Class: DIN6).



Collet Locking Mechanism

The input-end and the motor are coupled via a collet locking mechanism. With dynamic balance analysis, it ensures the features of stable concentricity, balance and non-backlash during power transmission at high speed.



Modular Design of Motor Connection Plate

The special modular design of the motor connection plate is made of aluminum alloy and is suitable for all series of Delta servomotors.



PS High Precision Series Features

The Delta Planetary Gearbox is made with high-tech design software, high-precision gear hobbing machines and comprehensive quality control to ensure all products provide highly accurate gear engagement, smooth performance and low noise.

- **High rigidity**

Uses high tensile strength alloy steel with gears processed by the vacuum carburization to ensure both core and surface hardness; the design enhances rigidity, extends gear service life and maintains high precision over a long period of operation

- **High precision**

- Backlash for concentric 1-stage gearbox: under 3 arcmin
- Backlash for right angle 1-stage gearbox: under 4 arcmin

- **High input speed**

Input speed: max. 5,000 rpm

- **High torque**

Higher output torque than spur gearbox with helical gear design

- **High efficiency**

- Efficiency for 1-stage model: exceeds 97%
- Efficiency for 2-stage model: exceeds 94%

- **Low noise**

Under 65dB

- **Lifetime lubrication**

Protective class IP65 sealed design avoids leakage problems and requires no maintenance during the product's lifetime



Model Name

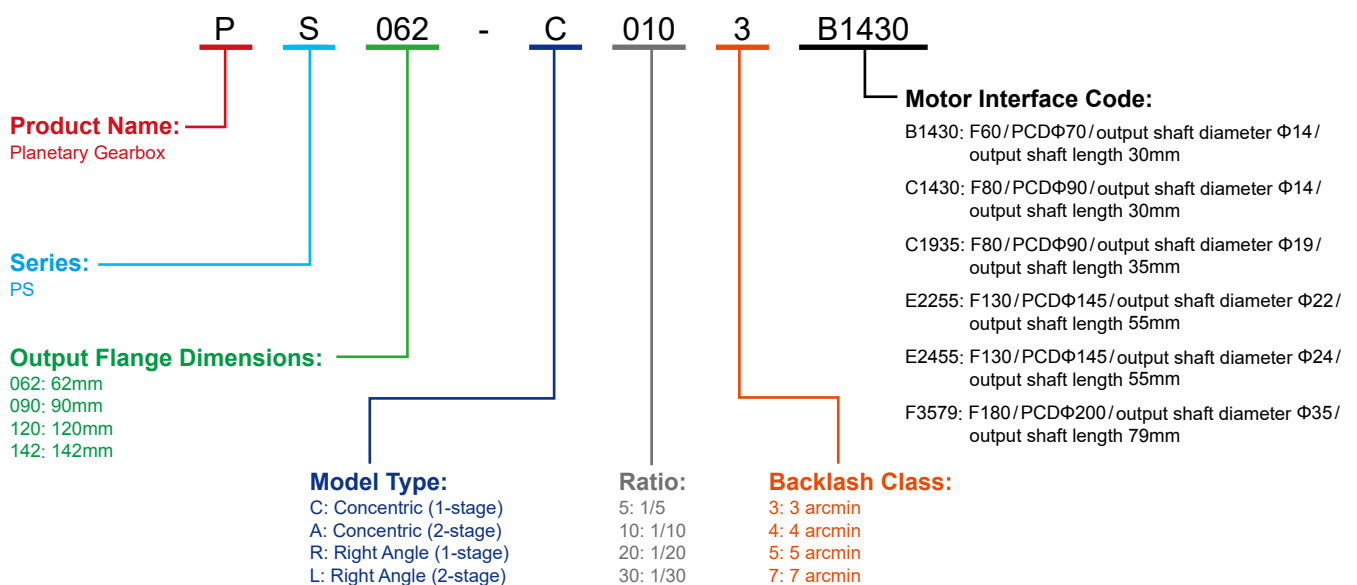

PS Series Compatible Motor Table

Type	Motor Frame Code	Power Rating	Output Shaft Diameter (S) & Length (LR) (mm)	Stage	Ratio	Backlash Class	Compatible Gearbox Model No.
Concentric	F60	200 W, 400 W	Φ14 / 30	1-stage	5, 10	3	PS062-CxxxxB1430
Concentric	F80	400 W, 750 W	Φ14 / 30	1-stage	5, 10	3	PS090-CxxxxC1430
Concentric	F80	750 W	Φ19 / 35	1-stage	5, 10	3	PS090-CxxxxC1935
Concentric	F130	300 W, 500 W, 600 W, 800 W, 900 W 1 kW, 1.3 kW, 1.5 kW, 1.8 kW, 2 kW	Φ22 / 55	1-stage	5, 10	3	PS120-CxxxxE2255
Concentric	F130	3 kW	Φ24 / 55	1-stage	5, 10	3	PS120-CxxxxE2455
Concentric	F180	2 kW, 3 kW, 3.5 kW, 4.5 kW	Φ35 / 79	1-stage	5, 10	3	PS142-CxxxxF3579
Concentric	F60	200 W, 400 W	Φ14 / 30	2-stage	20, 30	5	PS062-AxxxxB1430
Concentric	F80	400 W, 750 W	Φ14 / 30	2-stage	20, 30	5	PS090-AxxxxC1430
Concentric	F80	750 W	Φ19 / 35	2-stage	20, 30	5	PS090-AxxxxC1935
Concentric	F130	300 W, 500 W, 600 W, 800 W, 900 W 1 kW, 1.3 kW, 1.5 kW, 1.8 kW, 2 kW	Φ22 / 55	2-stage	20, 30	5	PS120-AxxxxE2255
Concentric	F130	3kW	Φ24 / 55	2-stage	20, 30	5	PS120-AxxxxE2455
Right-angle	F60	200 W, 400 W	Φ14 / 30	1-stage	5, 10	4	PS062-RxxxxB1430
Right-angle	F80	400 W, 750 W	Φ14 / 30	1-stage	5, 10	4	PS090-RxxxxC1430
Right-angle	F80	750 W	Φ19 / 35	1-stage	5, 10	4	PS090-RxxxxC1935
Right-angle	F130	300 W, 500 W, 600 W, 800 W, 900 W 1 kW, 1.3 kW, 1.5 kW, 1.8 kW, 2 kW	Φ22 / 55	1-stage	5, 10	4	PS120-RxxxxE2255
Right-angle	F130	3 kW	Φ24 / 55	1-stage	5, 10	4	PS120-RxxxxE2455
Right-angle	F180	2 kW, 3 kW, 3.5 kW, 4.5 kW	Φ35 / 79	1-stage	5, 10	4	PS142-RxxxxF3579
Right-angle	F60	200 W, 400 W	Φ14 / 30	2-stage	20, 30	7	PS062-LxxxxB1430
Right-angle	F80	400 W, 750 W	Φ14 / 30	2-stage	20, 30	7	PS090-LxxxxC1430
Right-angle	F80	750 W	Φ19 / 35	2-stage	20, 30	7	PS090-LxxxxC1935
Right-angle	F130	300 W, 500 W, 600 W, 800 W, 900 W 1 kW, 1.3 kW, 1.5 kW, 1.8 kW, 2 kW	Φ22 / 55	2-stage	20, 30	7	PS120-LxxxxE2255
Right-angle	F130	3 kW	Φ24 / 55	2-stage	20, 30	7	PS120-LxxxxE2455

Specifications

PS-C

Items	Unit	Ratio	62	90	120	142
Rated Output Torque	N-m	5	48	160	333	618
		10	43	141	294	549
Max. Acceleration Torque	N-m	5, 10	1.8 Times of Rated Output Torque			
Max. Output Torque	N-m	5, 10	3 Times of Rated Output Torque			
Rated Input Speed	rpm	5, 10	3,000	3,000	3,000	3,000
Max. Input Speed	rpm	5, 10	6,000	6,000	5,000	5,000
Backlash	arcmin	5, 10	≤3	≤3	≤3	≤3
Torsional Rigidity	N-m / arcmin	5, 10	6	14	27	60
Max. Radial Force	N	5, 10	1,180	3,200	6,800	9,300
Max. Axial Force	N	5, 10	590	1,600	3,400	4,650
Service Life	hr	5, 10	S5 Cycle Operation: >30,000 (S1 Continuous Operation: >15,000 hrs)			
Efficiency	%	5, 10	≥97			
Operating Temperature		5, 10	- 25°C ~ +90°C			
Lubrication		5, 10	Synthetic Grease			
Protection Class		5, 10	IP65			
Mounting Position		5, 10	Any			
Noise Level	dB	5, 10	≤58	≤60	≤63	≤65
Weight	kg	5, 10	1.35	3.6	8	14.3
Mass Moment of Inertia	kg.cm ²	5	0.13	0.47	2.71	7.42
		10	0.13	0.44	2.57	7.03

Dimensions

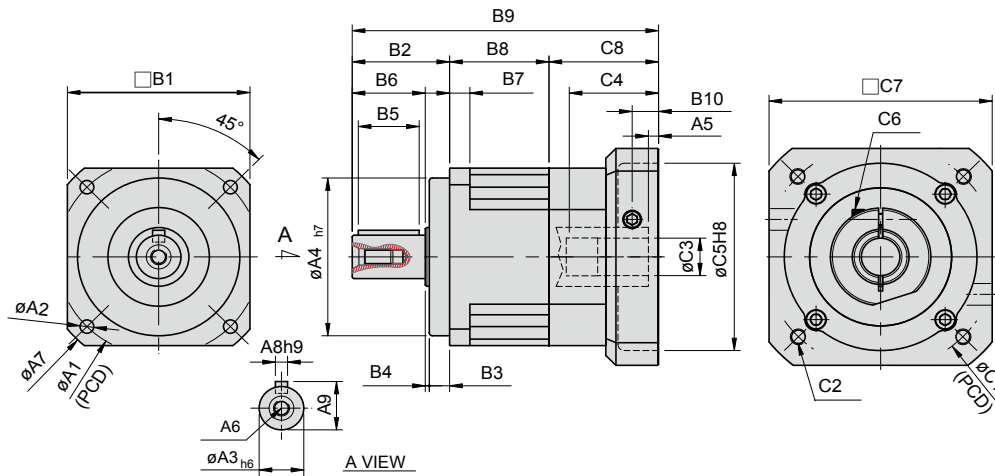

PS-C

Items	62	90	120	142
A1	70	100	130	165
A2	5.5	6.8	9	11
A3	16	22	32	40
A4	50	80	110	130
A5	6	9	10	10
A6	M5 x P0.8	M8 x P1.25	M10 x P1.5	M12 x P1.75
A7	80	116	148	186
A8	5	6	10	12
A9	18	24.5	35	43
B1	62	90	120	142
B2	36	48	65	92
B3	7	10	12	15
B4	1	2	3	3
B5	20	30	40	65
B6	28	36	50	74
B7	8	10	12	15
B8	38	49	61	70
B9	115	164.5	205	260.5
B10	11.5	16	19.5	20
C1	70	90	145	200
C2	M5	M6	M8	M12
C3	14	19	24	35
C4	33.5	59	67	84.5
C5	50	70	110	114.3
C6	M5 x P0.8	M6 x P1.0	M8 x P1.25	M10 x P1.5
C7	64	92	130	180
C8	41	67.5	79	98.5

Specifications

PS-A

Items	Unit	Ratio	62	90	120
Rated Output Torque	N-m	20	51	146	300
		30	45	151	311
Max. Acceleration Torque	N-m	20, 30	1.8 Times of Rated Output Torque		
Max. Output Torque	N-m	20, 30	3 Times of Rated Output Torque		
Rated Input Speed	rpm	20, 30	3,000	3,000	3,000
Max. Input Speed	rpm	20, 30	6,000	6,000	5,000
Backlash	arcmin	20, 30	≤5	≤5	≤5
Torsional Rigidity	N-m / arcmin	20, 30	6	14	27
Max. Radial Force	N	20, 30	1,180	3,200	6,800
Max. Axial Force	N	20, 30	590	1,600	3,400
Service Life	hr	20, 30	S5 Cycle Operation: >30,000 (S1 Continuous Operation: >15,000 hrs)		
Efficiency	%	20, 30	≥94		
Operating Temperature		20, 30	- 25°C ~ +90°C		
Lubrication		20, 30	Synthetic Grease		
Protection Class		20, 30	IP65		
Mounting Position		20, 30	Any		
Noise Level	dB	20, 30	≤58	≤60	≤63
Weight	kg	20, 30	2	5.5	11
Mass Moment of Inertia	kg.cm ²	20	0.14	0.46	2.63
		30	0.14	0.46	2.43

Dimensions

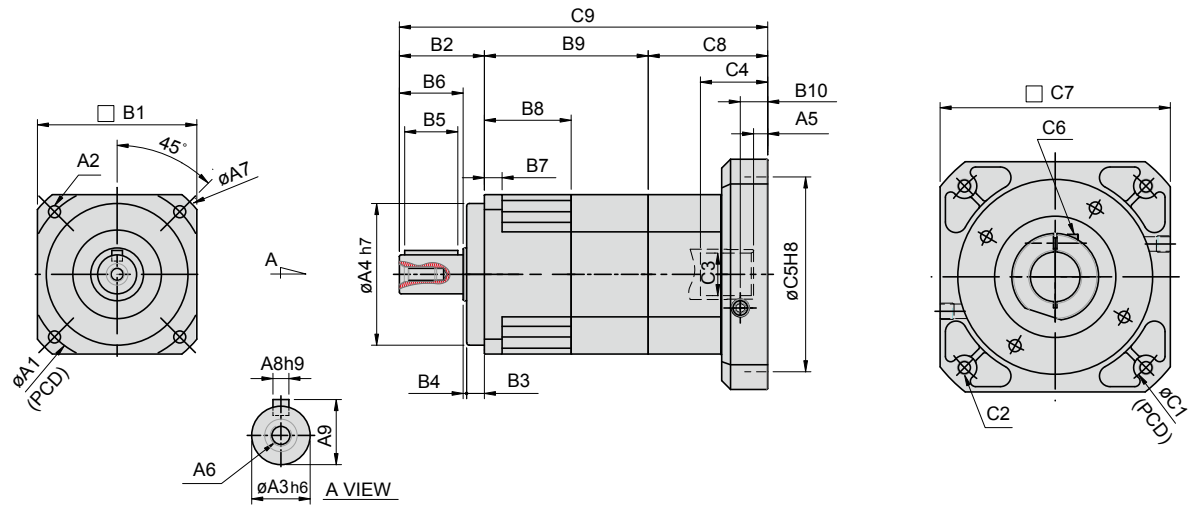

PS-A

Items	62	90	120
A1	70	100	130
A2	5.5	6.8	9
A3	16	22	32
A4	50	80	110
A5	6	9	10
A6	M5 x P0.8	M8 x P1.25	M10 x P1.5
A7	80	116	148
A8	5	6	10
A9	18	24.5	35
B1	62	90	120
B2	36	48	65
B3	7	10	12
B4	1	2	3
B5	20	30	40
B6	28	36	50
B7	8	10	12
B8	38	49	61
B9	71.8	92.5	117
B10	11.5	16	19.5
C1	70	90	145
C2	M5	M6	M8
C3	14	19	24
C4	33.5	59	67
C5	50	70	110
C6	M5 x P0.8	M6 x P1.0	M8 x P1.25
C7	64	92	130
C8	41	67.5	79
C9	148.8	208	261

Specifications

PS-R

Items	Unit	Ratio	62	90	120	142
Rated Output Torque	N-m	5	48	160	333	618
		10	43	141	294	549
Max. Acceleration Torque	N-m	5, 10	1.8 Times of Rated Output Torque			
Max. Output Torque	N-m	5, 10	3 Times of Rated Output Torque			
Rated Input Speed	rpm	5, 10	3,000	3,000	3,000	3,000
Max. Input Speed	rpm	5, 10	6,000	6,000	5,000	5,000
Backlash	arcmin	5, 10	≤4	≤4	≤4	≤4
Torsional Rigidity	N-m / arcmin	5, 10	6	14	27	60
Max. Radial Force	N	5, 10	1,180	3,200	6,800	9,300
Max. Axial Force	N	5, 10	590	1,600	3,400	4,650
Service Life	hr	5, 10	S5 Cycle Operation: >30,000 (S1 Continuous Operation: >15,000 hrs)			
Efficiency	%	5, 10	≥95			
Operating Temperature		5, 10	- 25°C ~ +90°C			
Lubrication		5, 10	Synthetic Grease			
Protection Class		5, 10	IP65			
Mounting Position		5, 10	Any			
Noise Level	dB	5, 10	≤68	≤70	≤72	≤74
Weight	kg	5, 10	2.3	6.6	13.8	52.8
Mass Moment of Inertia	kg.cm ²	5	0.36	2.28	6.85	23.5
		10	0.36	2.28	6.85	23.5

Dimensions

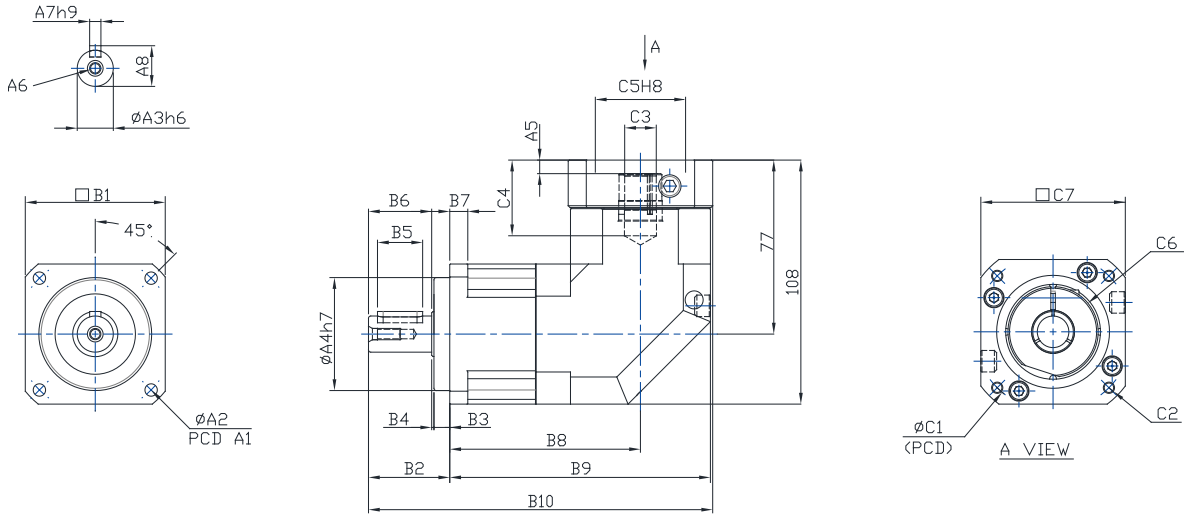

PS-R

Items	62	90	120	142
A1	70	100	130	165
A2	5.5	6.8	9	11
A3	16	22	32	40
A4	50	80	110	130
A5	6	9	10	10
A6	M5xP0.8	M8xP1.25	M10xP1.5	M12xP1.75
A7	5	6	10	12
A8	18	24.5	35	43
B1	62	90	120	142
B2	36	48	65	92
B3	7	10	12	15
B4	1	2	3	3
B5	20	30	40	65
B6	28	36	50	74
B7	8	10	12	15
B8	84.5	122.1	148	165.5
B9	115.5	167.1	208	236.5
B10	152.5	216.1	278	347.5
C1	70	90	145	200
C2	M5	M6	M8	M12
C3	14	19	24	35
C4	33.5	53	67	85
C5	50	70	110	114.3
C6	M5 x P0.8	M6 x P1.0	M8 x P1.25	M10 x P1.5
C7	64	92	130	180
C8	21.5	26.5	35.5	35.5
C9	77	115.3	141	174
C10	108	160.3	201	245

Specifications

PS-L

Items	Unit	Ratio	62	90	120
Rated Output Torque	N-m	20	51	146	300
		30	45	151	311
Max. Acceleration Torque	N-m	20, 30	1.8 Times of Rated Output Torque		
Max. Output Torque	N-m	20, 30	3 Times of Rated Output Torque		
Rated Input Speed	rpm	20, 30	3,000	3,000	3,000
Max. Input Speed	rpm	20, 30	6,000	6,000	5,000
Backlash	arcmin	20, 30	≤7	≤7	≤7
Torsional Rigidity	N-m / arcmin	20, 30	6	14	27
Max. Radial Force	N	20, 30	1,180	3,200	6,800
Max. Axial Force	N	20, 30	590	1,600	3,400
Service Life	hr	20, 30	S5 Cycle Operation: >30,000 (S1 Continuous Operation: >15,000 hrs)		
Efficiency	%	20, 30	≥92		
Operating Temperature		20, 30	– 25°C ~ +90°C		
Lubrication		20, 30	Synthetic Grease		
Protection Class		20, 30	IP65		
Mounting Position		20, 30	Any		
Noise Level	dB	20, 30	≤68	≤70	≤72
Weight	kg	20, 30	3	8.2	12.5
Mass Moment of Inertia	kg.cm ²	20	0.36	2.28	6.85
		30	0.36	2.28	6.85

Dimensions

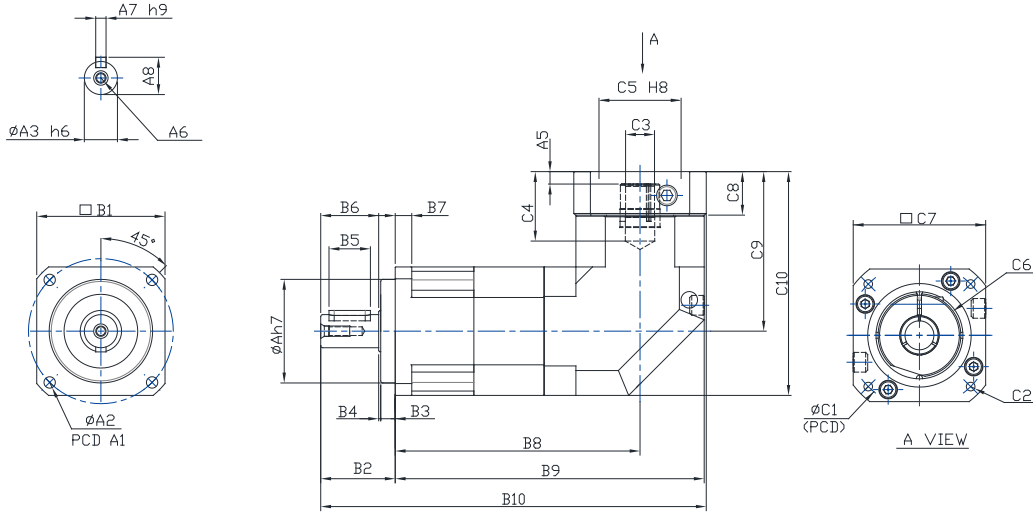

PS-L

Items	62	90	120
A1	70	100	130
A2	5.5	6.8	9
A3	16	22	32
A4	50	80	110
A5	6	9	10
A6	M5xP0.8	M8xP1.25	M10xP1.5
A7	5	6	10
A8	18	24.5	35
B1	62	90	120
B2	36	48	65
B3	7	10	12
B4	1	2	3
B5	20	30	40
B6	28	36	50
B7	8	10	12
B8	118.3	165.6	204
B9	149.3	210.6	264
B10	185.3	258.6	329
C1	70	90	145
C2	M5	M6	M8
C3	14	19	24
C4	33.5	53	67
C5	50	70	110
C6	M5xP0.8	M6xP1.0	M8xP1.25
C7	64	92	130
C8	21.5	26.5	35.5
C9	77	115.3	141
C10	108	160.3	201

PA Precision Series Features

- **High rigidity and high torque**

Employs uncaged needle roller bearings with a set design including ring teeth, gearbox and helical gears for high rigidity and output torque

- **High precision**

- Backlash for 1-stage gearbox is under 8 arcmin
- Backlash for 2-stage gearbox is under 12 arcmin

- **High efficiency**

- Efficiency for 1-stage model exceeds 95%
- Efficiency for 2-stage model exceeds 92%

- **Low noise**

Uses helical gears, which are capable of meshing to ensure smooth and quiet operation

- **Lifetime lubrication**

Protective class IP65 sealed design avoids leakage problems and requires no maintenance during the product's lifetime



Model Name

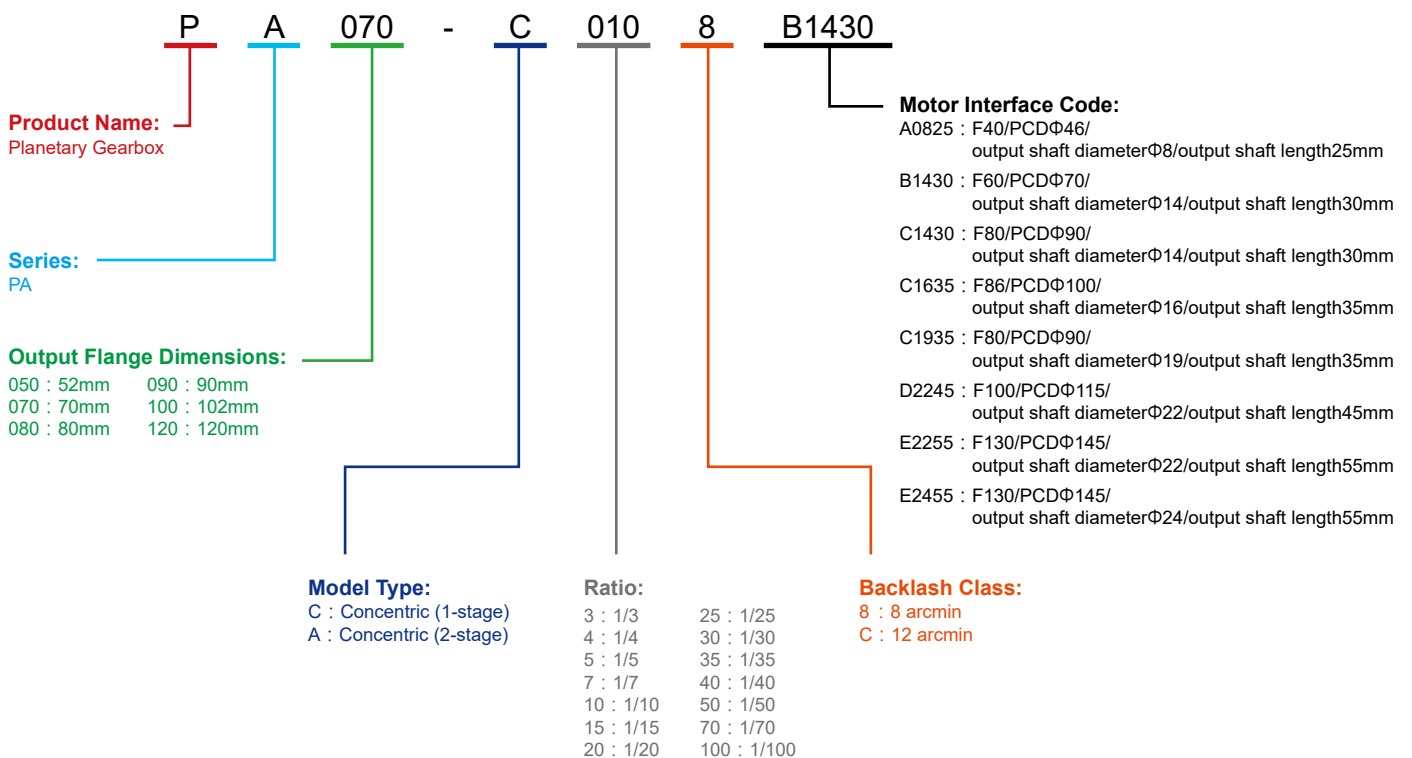

PA Series Compatible Motor Table

Type	Motor Frame Code	Power Rating	Output Shaft Diameter (S) & Length (LR) (mm)	Stage	Ratio	Backlash Class	Compatible Gearbox Model No.
Concentric	F40	50W, 100W	Φ8 / 25	1-stage	3, 4, 5, 7, 10	8	PA050-CxxxxA0825
Concentric	F60	200W, 400W	Φ14 / 30	1-stage	3, 4, 5, 7, 10	8	PA050-CxxxxB1430 PA070-CxxxxB1430 PA080-CxxxxB1430
Concentric	F80	400W	Φ14 / 30	1-stage	3, 4, 5, 7, 10	8	PA080-CxxxxC1430 PA100-CxxxxC1430
Concentric	F80	750W	Φ19 / 35	1-stage	3, 4, 5, 7, 10	8	PA080-CxxxxC1935 PA090-CxxxxC1935
Concentric	F86	750W, 1kW	Φ16 / 35	1-stage	3, 4, 5, 7, 10	8	PA080-CxxxxC1635 PA090-CxxxxC1635 PA100-CxxxxC1635
Concentric	F100	1kW, 2kW	Φ22 / 45	1-stage	3, 4, 5, 7, 10	8	PA100-CxxxxD2245
Concentric	F130	300W, 500W, 600W, 800W, 900W 1kW, 1.3kW, 1.5kW, 1.8kW, 2kW	Φ22 / 55	1-stage	3, 4, 5, 7, 10	8	PA100-CxxxxE2255
Concentric	F130	3kW	Φ24 / 55	1-stage	3, 4, 5, 7, 10	8	PA100-CxxxxE2455 PA120-CxxxxE2455
Concentric	F40	50W, 100W	Φ14 / 30	2-stage	10, 15, 20, 25, 30, 35, 40,50,70,100	12	PA050-AxxxxA0825
Concentric	F60	200W, 400W	Φ14 / 30	2-stage	10, 15, 20, 25, 30, 35, 40,50,70,100	12	PA050-AxxxxB1430 PA070-AxxxxB1430 PA080-AxxxxB1430
Concentric	F80	400W	Φ14 / 30	2-stage	10, 15, 20, 25, 30, 35, 40,50,70,100	12	PA080-AxxxxC1430 PA100-AxxxxC1430
Concentric	F80	750W	Φ19 / 35	2-stage	10, 15, 20, 25, 30, 35, 40,50,70,100	12	PA080-AxxxxC1935 PA090-AxxxxC1935
Concentric	F86	750W, 1kW	Φ16 / 35	2-stage	10, 15, 20, 25, 30, 35, 40,50,70,100	12	PA080-AxxxxC1635 PA090-AxxxxC1635 PA100-AxxxxC1635
Concentric	F100	1kW, 2kW	Φ22 / 45	2-stage	10, 15, 20, 25, 30, 35, 40,50,70,100	12	PA100-AxxxxD2245
Concentric	F130	300W, 500W, 600W, 800W, 900W 1kW, 1.3kW, 1.5kW, 1.8kW, 2kW	Φ22 / 55	2-stage	10, 15, 20, 25, 30, 35, 40,50,70,100	12	PA100-AxxxxE2255
Concentric	F130	3kW	Φ24 / 55	2-stage	10, 15, 20, 25, 30, 35, 40,50,70,100	12	PA100-AxxxxE2455 PA120-AxxxxE2455

Specifications

PA Series

Items	Unit	Stage	Ratio	50	70	80	90	100	120
Rated Output Torque	N-m	1	3	19	54	112	112	165	286
			4	16	48	110	110	146	255
			5	16	45	108	108	160	264
			7	15	41	105	105	149	245
			10	14	40	100	100	141	234
		2	15	19	54	112	112	165	286
			20	16	48	110	110	146	255
			25	16	45	108	108	160	264
			30	19	41	112	112	165	286
			35	15	41	105	105	149	245
			40	16	39	110	110	146	255
			50	16	45	108	108	160	264
			70	15	41	105	105	149	245
			100	14	40	100	100	141	234
Max. Acceleration Torque	N-m	1,2	3 ~ 100	1.8 Times the Rated Output Torque					
Max. Output Torque	N-m	1,2	3 ~ 100	3 Times the Rated Output Torque					
Rated Input Speed	rpm	1,2	3 ~ 100	3,000					
Max. Input Speed	rpm	1,2	3 ~ 100	5,000					
Backlash	arcmin	1	3 ~ 10	≤8					
	arcmin	2	15 ~ 100	≤12					
Torsional Rigidity	N-m/arcmin	1,2	3 ~ 100	3	5	12	12	14	23
Max. Radial Force	N	1,2	3 ~ 100	350	800	1,200	1,200	3,200	5,220
Max. Axial Force	N	1,2	3 ~ 100	180	400	600	600	1,600	1,600
Service Life	hr	1,2	3 ~ 100	S5 Cycle Operation: > 20,000 (S1 Continuous Operation: > 10,000 hrs)					
Efficiency	%	1	3 ~ 10	≥97					
		2	15 ~ 100	≥95					
Operating Temperature		1,2	3 ~ 100	- 25°C ~ +90°C					
Lubrication		1,2	3 ~ 100	Synthetic Grease					
Protection Class		1,2	3 ~ 100	IP65					
Mounting Position		1,2	3 ~ 100	Any					
Noise Level	dB	1	3 ~ 10	≤58	≤58	≤60	≤60	≤65	≤67
		2	15 ~ 100	≤60	≤60	≤62	≤62	≤67	≤69
Weight ±2%	kg	1	3 ~ 10	0.64	1.6	1.6	1.96	3.76	7.43
		2	15 ~ 100	0.96	2.1	2.8	3.06	5.92	10.3

Mass Moment of Inertia

Items	Unit	Stage	Ratio	50	70	80	90	100	120
Mass Moment of Inertia	kg.cm ²	1	3	0.03	0.16	0.48	0.48	0.6	3.21
			4	0.03	0.14	0.38	0.38	0.45	2.64
			5	0.03	0.13	0.38	0.38	0.45	2.64
			7	0.03	0.13	0.38	0.38	0.45	2.62
			10	0.03	0.13	0.35	0.35	0.41	2.51
		2	15	0.03	0.13	0.41	0.41	0.45	2.64
			20~40	0.03	0.13	0.38	0.38	0.45	2.64
			50~100	0.03	0.13	0.38	0.38	0.45	2.51
				0.03	0.13	0.38	0.38	0.45	2.51

Dimensions

PA50 1-stage

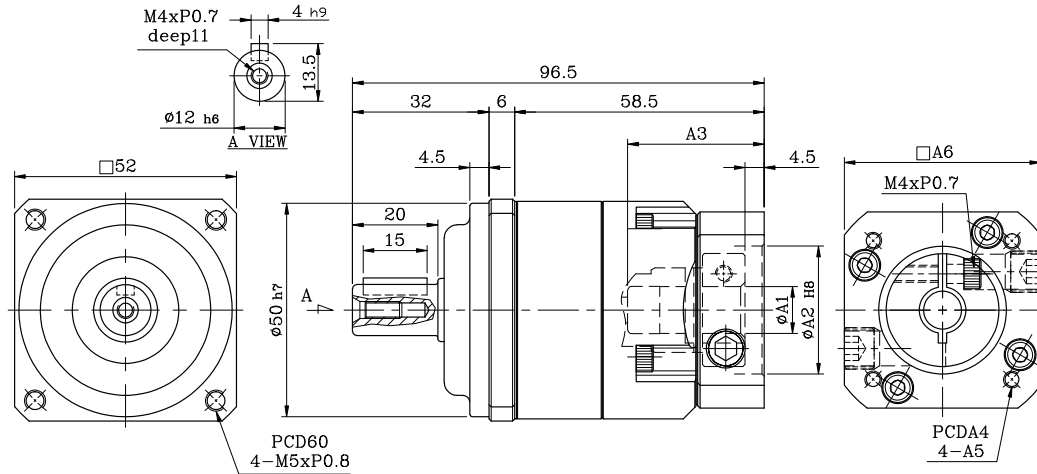

	Motor Interface Code	$\Phi A1$	$\Phi A2$	A3	A4	A5	A6
PA50	A0825	8	30	32	46	M4	46
	B1430	14	50	32	70	M5	60

PA50 2-stage

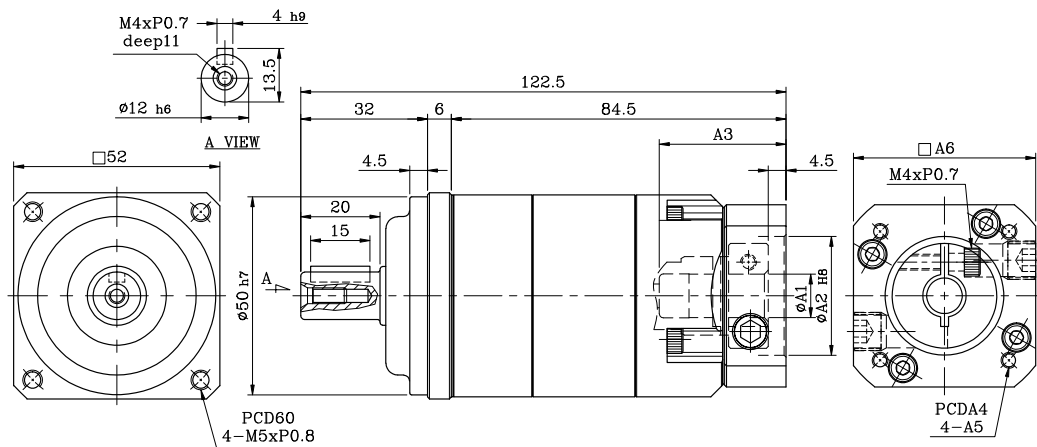

	Motor Interface Code	$\Phi A1$	$\Phi A2$	A3	A4	A5	A6
PA50	A0825	8	30	32	46	M4	46
	B1430	14	50	32	70	M5	60

Dimensions

PA70 1-stage

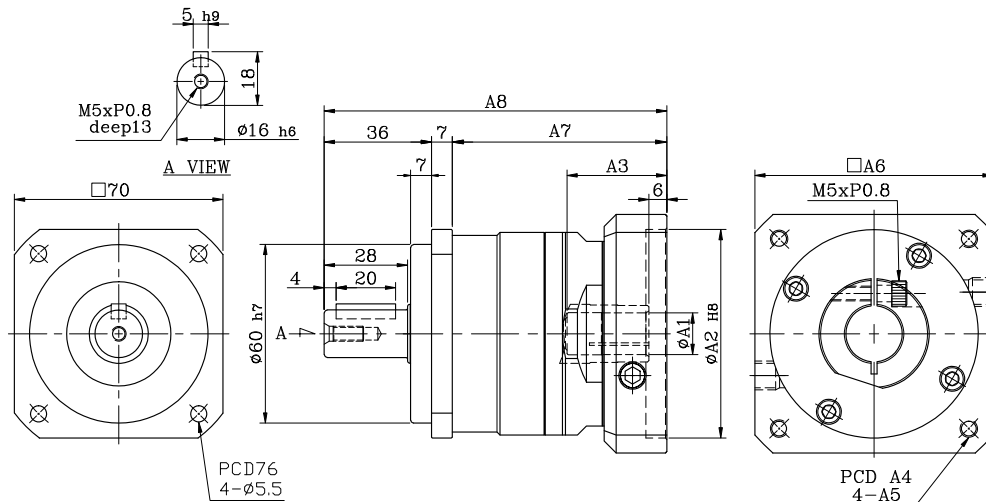

	Motor Interface Code	$\Phi A1$	$\Phi A2$	A3	A4	A5	A6	A7	A8
PA70	B1430	14	50	33.5	70	M5	64	72	115

PA70 2-stage

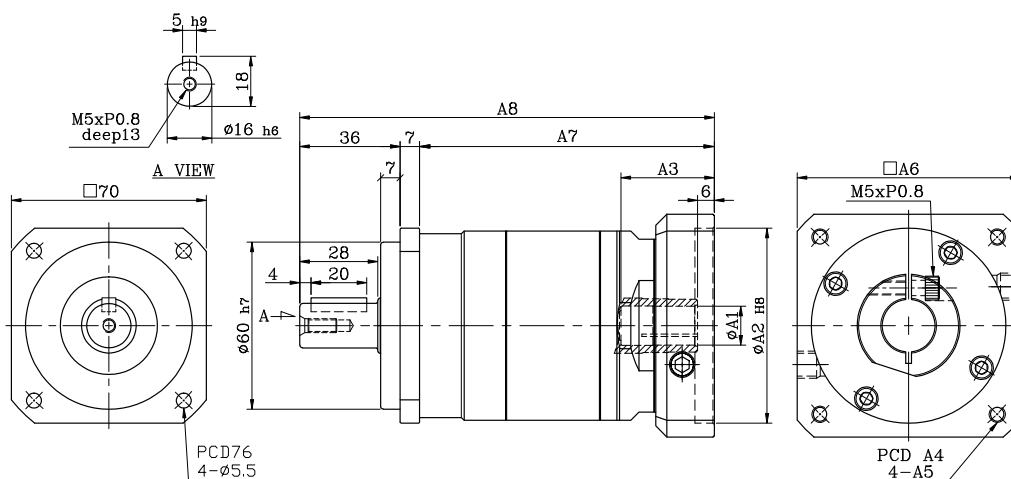

	Motor Interface Code	$\Phi A1$	$\Phi A2$	A3	A4	A5	A6	A7	A8
PA70	B1430	14	50	33.5	70	M5	64	72	115

Dimensions

PA80 1-stage

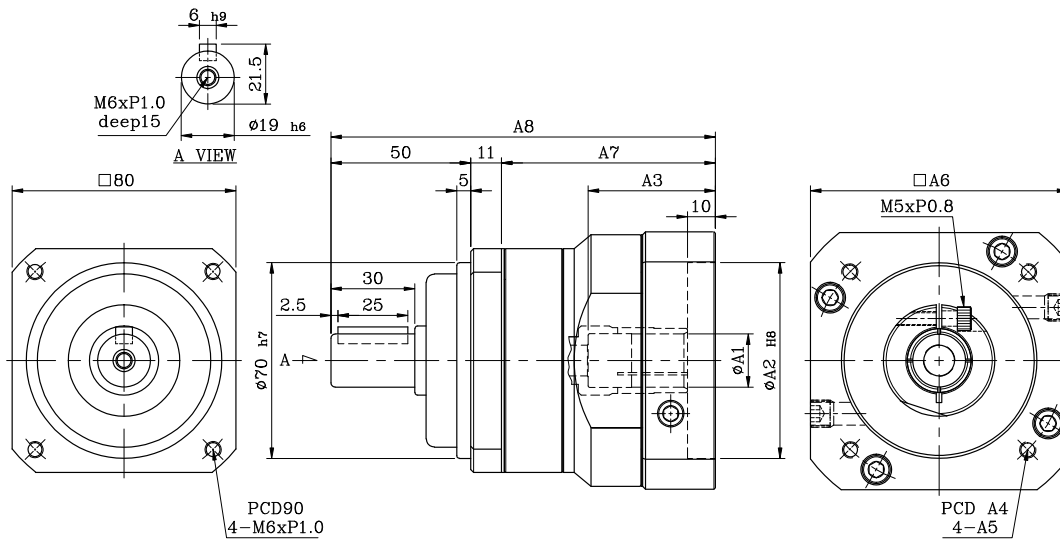

	Motor Interface Code	Φ A1	Φ A2	A3	A4	A5	A6	A7	A8
PA80	B1430	14	50	33.5	70	M5	92	64.5	125.5
PA80	C1430	14	70	45.5	90	M6	92	76.5	137.5
PA80	C1935	19	70	45.5	90	M6	92	76.5	137.5
PA80	C1635	19	80	45.5	100	M6	92	76.5	137.5

PA80 2-stage

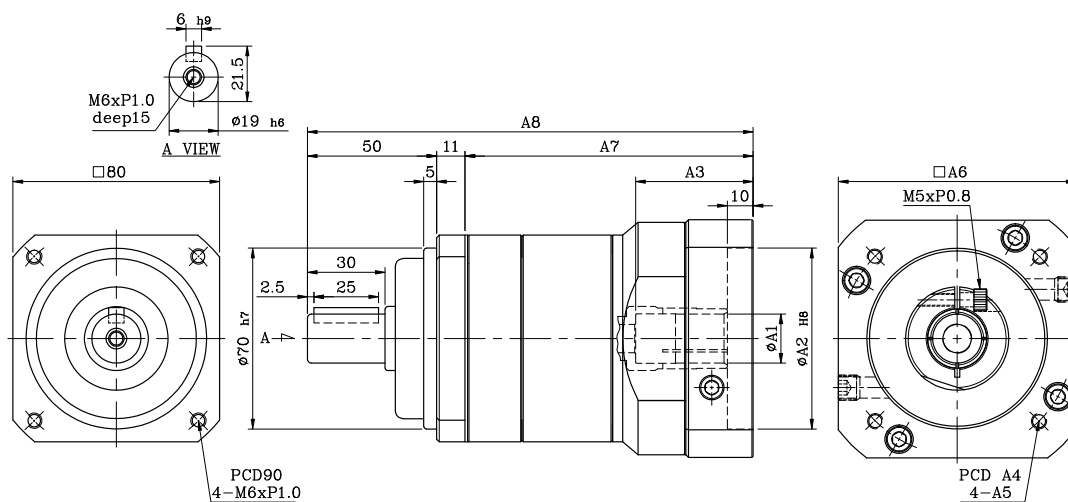

	Motor Interface Code	Φ A1	Φ A2	A3	A4	A5	A6	A7	A8
PA80	B1430	14	50	33.5	70	M5	92	99.5	160.5
PA80	C1430	14	70	45.5	90	M6	92	111.5	172.5
PA80	C1935	19	70	45.5	90	M6	92	111.5	172.5
PA80	C1635	19	80	45.5	100	M6	92	111.5	172.5

Dimensions

PA90 1-stage

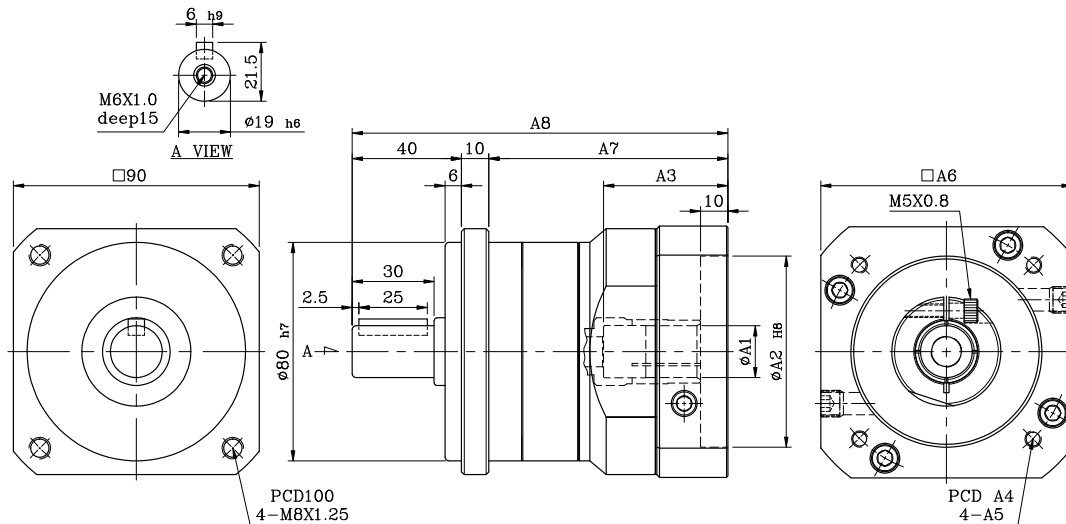

	Motor Interface Code	Φ A1	Φ A2	A3	A4	A5	A6	A7	A8
PA90	C1935	19	70	45.5	90	M6	92	87.5	137.5
PA90	C1635	19	80	45.5	100	M6	92	87.5	137.5

PA90 2-stage

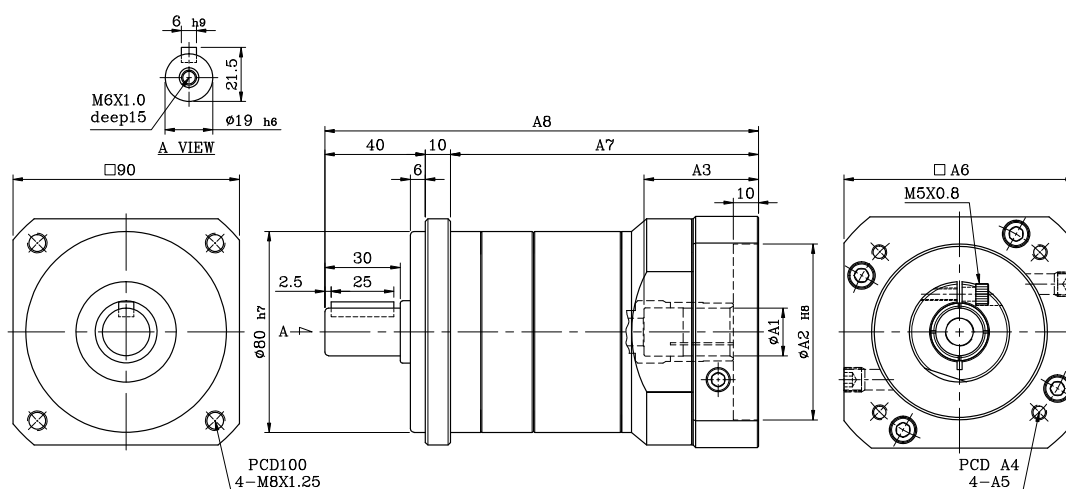

	Motor Interface Code	Φ A1	Φ A2	A3	A4	A5	A6	A7	A8
PA90	C1935	19	70	45.5	90	M6	92	122.5	172.5
PA90	C1635	19	80	45.5	100	M6	92	122.5	172.5

Dimensions

PA100 1-stage

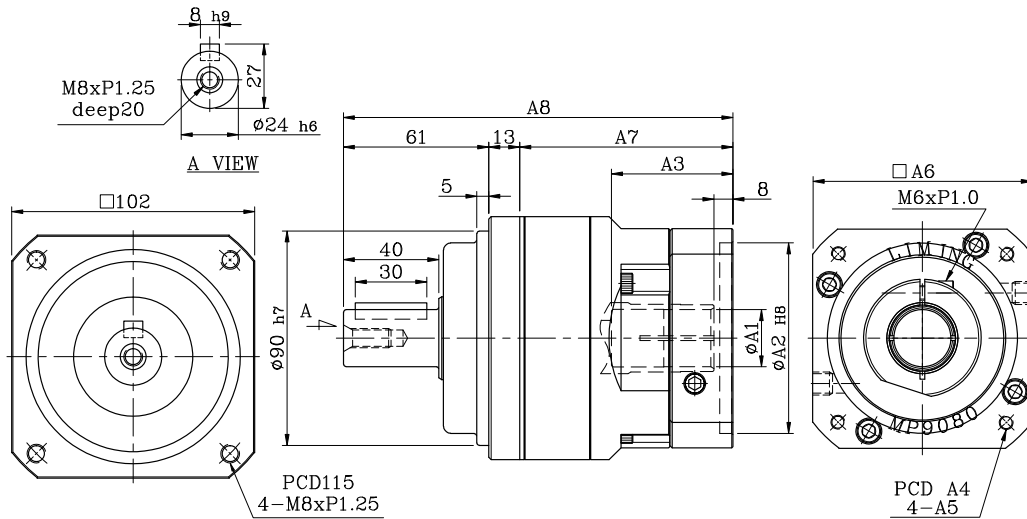

	Motor Interface Code	Φ A1	Φ A2	A3	A4	A5	A6	A7	A8
PA100	C1430	14	70	51	90	M6	92	89.5	163.5
PA100	C1635	19	80	51	100	M6	92	89.5	163.5
PA100	D2245	22	95	51	115	M6	110	89.5	163.5
PA100	E2255	22	110	51	145	M8	130	89.5	163.5
PA100	E2455	24	110	65.5	145	M8	130	104	178

PA100 2-stage

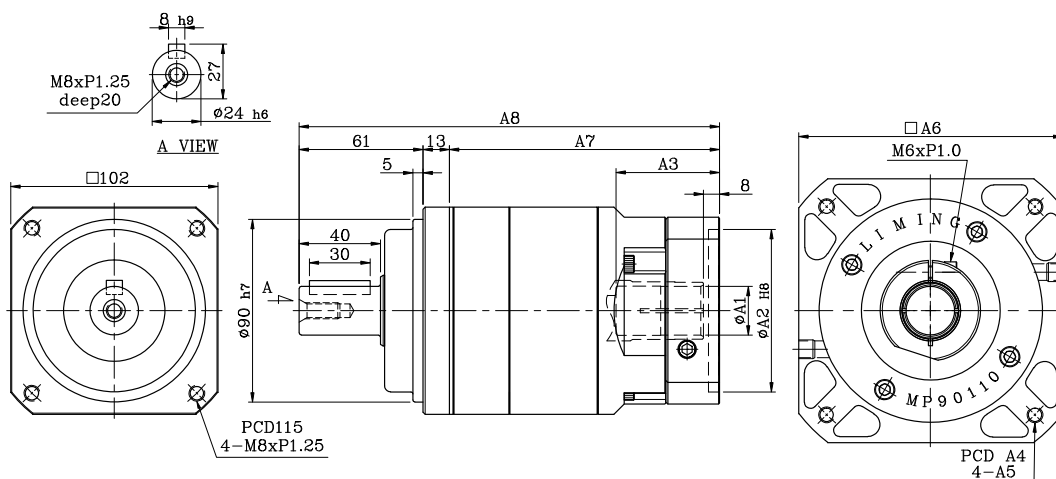

	Motor Interface Code	Φ A1	Φ A2	A3	A4	A5	A6	A7	A8
PA100	C1430	14	70	51	90	M6	92	133	207
PA100	C1635	19	80	51	100	M6	92	133	207
PA100	D2245	22	95	51	115	M6	110	133	207
PA100	E2255	22	110	51	145	M8	130	133	207
PA100	E2455	24	110	65.5	145	M8	130	147.5	221.5

Dimensions

PA120 1-stage

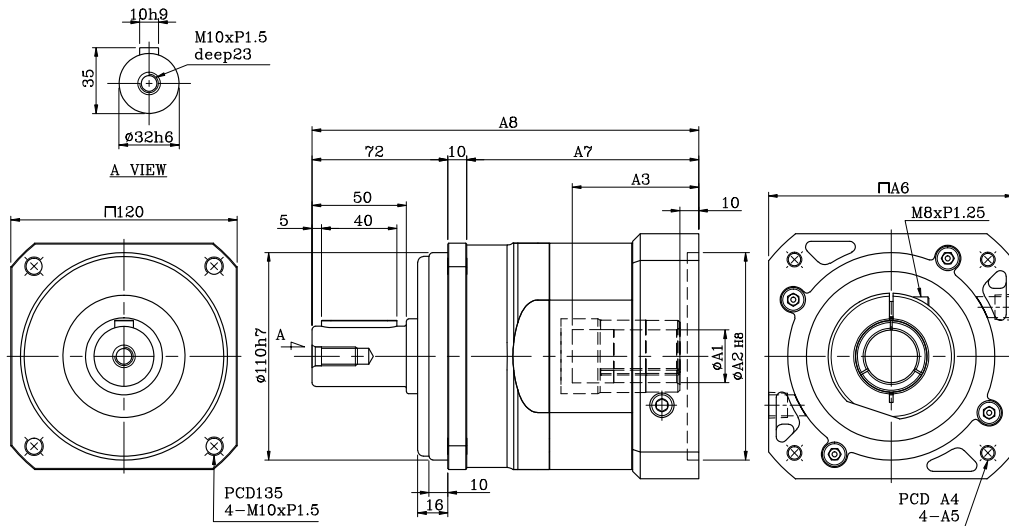

	Motor Interface Code	Φ A1	Φ A2	A3	A4	A5	A6	A7	A8
PA120	E2455	24	110	67	145	M8	130	123	205

PA120 2-stage

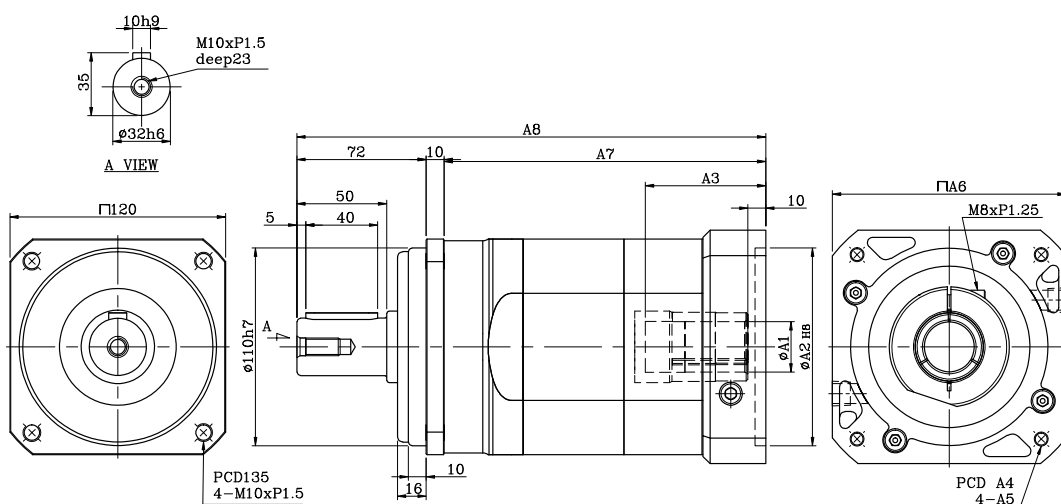

	Motor Interface Code	Φ A1	Φ A2	A3	A4	A5	A6	A7	A8
PA120	E2455	24	110	67	145	M8	130	123	205

Calculation Method

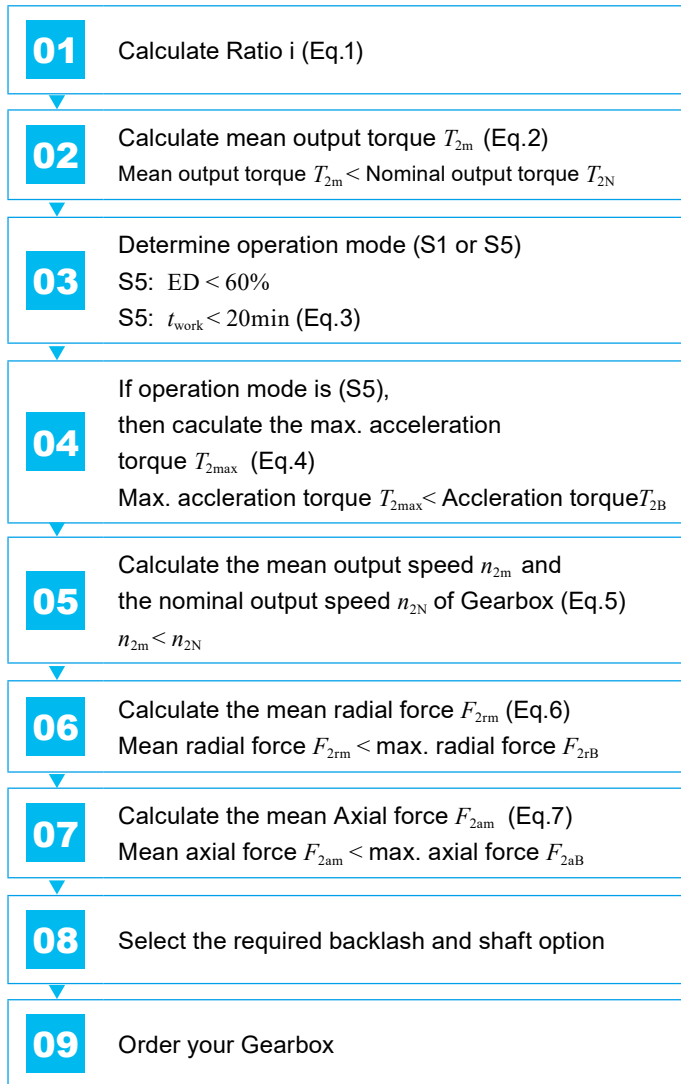

Recommended options for S5 Cyclic Operation:

The general design is given for

$$\frac{J_L}{i^2} \leq 4 \cdot J_m$$

The optimal design is given for

$$\frac{J_L}{i^2} \cong J_m$$

Where J_L is Load Inertia and J_m is Motor Inertia

T_{2n} : please refer to catalog "Rated Output Torque"

F_{2rB} : please refer to catalog "Max. Radial Force"

Eq. 1 $i \cong \frac{n_m}{n_{work}}$

n_m is output speed of the motor
 n_{work} is working speed

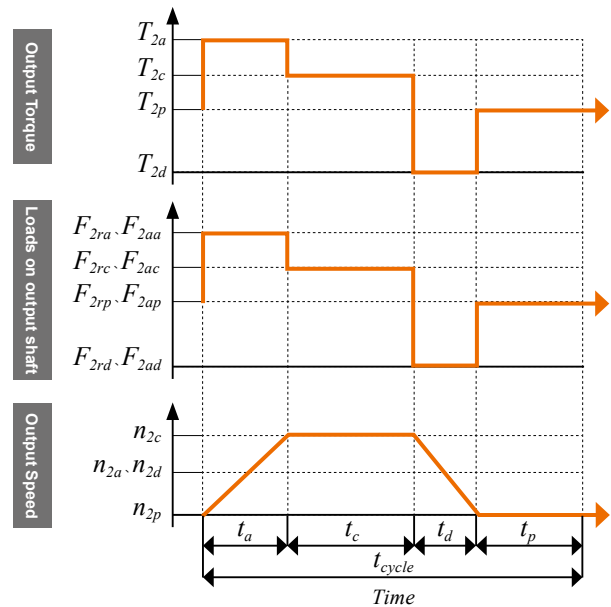

Eq. 2
$$T_{2m} = \sqrt[3]{\frac{n_{2a} \cdot t_a \cdot T_{2a}^3 + n_{2c} \cdot t_c \cdot T_{2c}^3 + n_{2d} \cdot t_d \cdot T_{2d}^3}{n_{2a} \cdot t_a + n_{2c} \cdot t_c + n_{2d} \cdot t_d}}$$

Eq. 3
$$ED = \frac{t_a + t_c + t_d}{t_{cycle}} \cdot t_{work} = t_a + t_c + t_d$$

t_a is the time for acceleration; t_c is constant travel
 t_d is the time for deceleration; t_p is the time for pause

Eq. 4
$$T_{2max} = T_{mB} \cdot i \cdot k_s \cdot \eta$$

 T_{mB} is the max. output torque of the motor and η is the efficiency of the gearbox

k_s service factor	
k_s	No. of cycles / hr
1.0	0 ~ 1,000
1.1	1,000 ~ 1,500
1.3	1,500 ~ 2,000
1.6	2,000 ~ 3,000
1.8	3,000 ~ 5,000

Eq. 5
$$n_{2a} = n_{2d} = \frac{n_{2c}}{2}$$

$$n_{2m} = \frac{n_{2a} \cdot t_a + n_{2c} \cdot t_c + n_{2d} \cdot t_d}{t_a + t_c + t_d}$$

$$n_{2N} = \frac{n_{1N}}{i}$$

Eq. 6
$$F_{2rm} = \sqrt[3]{\frac{n_{2a} \cdot t_a \cdot F_{2ra}^3 + n_{2c} \cdot t_c \cdot F_{2rc}^3 + n_{2d} \cdot t_d \cdot F_{2rd}^3}{n_{2a} \cdot t_a + n_{2c} \cdot t_c + n_{2d} \cdot t_d}}$$

Eq. 7
$$F_{2am} = \sqrt[3]{\frac{n_{2a} \cdot t_a \cdot F_{2aa}^3 + n_{2c} \cdot t_c \cdot F_{2ac}^3 + n_{2d} \cdot t_d \cdot F_{2ad}^3}{n_{2a} \cdot t_a + n_{2c} \cdot t_c + n_{2d} \cdot t_d}}$$

Collet Screw & Set Collar Torque Table

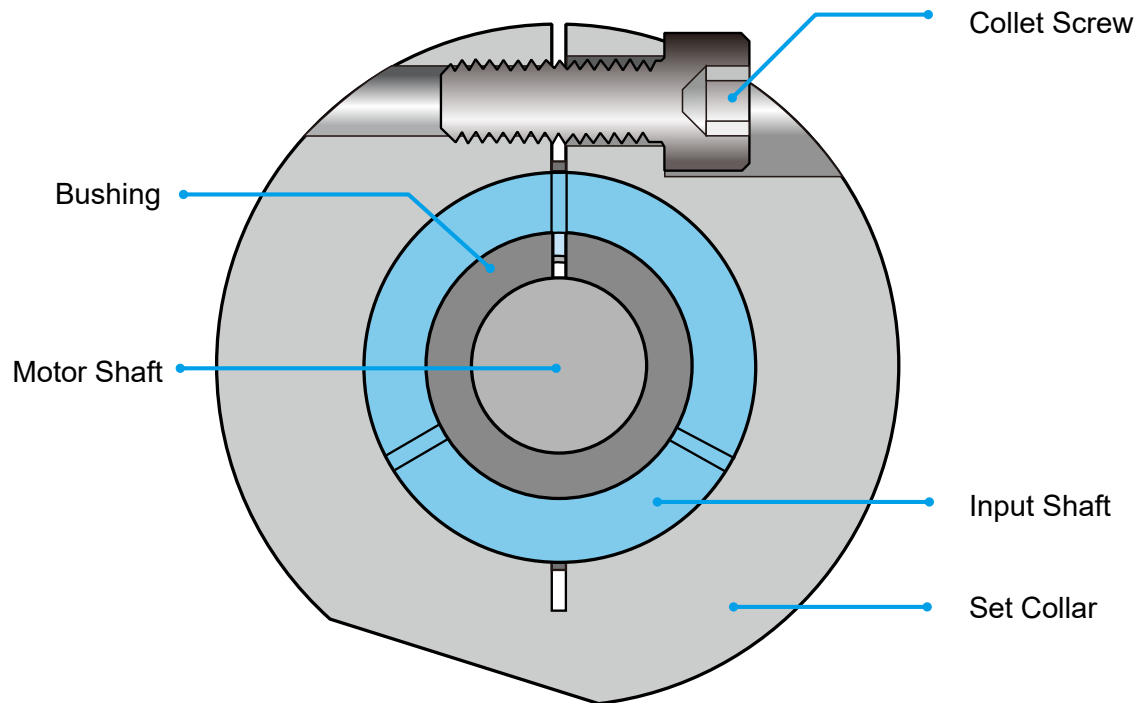

Frame		Collet Screw Specifications	Screw Grade	Screw Tighten Torque (N-m)	Wrench Torque (N-m)
PS	PA				
	50	M3 x P 0.5	12.9	2.2	58
62	70	M5 x P 0.8	12.9	10	164
	80				
	90				
90	100	M6 x P 1.0	12.9	16.3	233
120	120	M8 x P 1.25	12.9	41	423
142		M10 x P 1.5	12.9	81	678

Installation Instructions

Assembling the Planetary Gearbox with Motor



01

Confirm the compatibility of motor model and gearbox spec and clean the mounting surface



02

Remove the motor key



03

Check the motor shaft size (Insert the bushing into the input bore if necessary)



04

Remove the plug into the adapter plate. Loosen the set collar with a torque wrench and align with the bolt

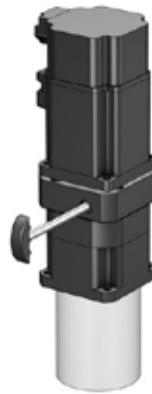

05

Vertically insert motor from the gearbox

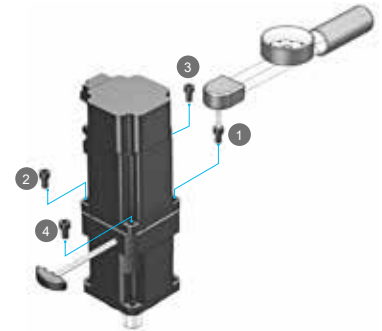

06

Tighten the mounting bolts from bolt 1 to bolt 4 with the torque wrench



07

Tighten the set collar bolt with the torque wrench



08

Assemble with the screw plug

! Caution

1. Please tighten the motor before fastening the set collar on the motor shaft

2. Please follow the instructions in order for assembly. Do not randomly change the steps

Global Operations

ASIA (Taiwan)



Taoyuan Technology Center (Green Building)



Taoyuan Plant 1



Tainan Plant (Diamond-rated Green Building)

ASIA (China)



Wujiang Plant 3



Delta Electronics



ASIA (Japan)



Tokyo Office



ASIA (India)



Rudrapur Plant
(Green Building)

EUROPE



Amsterdam, Netherlands

AMERICA



Research Triangle Park

▲ Factories 5 ■ Branch Offices 102 ● R&D Centers 6 ■ Distributors 824

Europe

Russia
Moscow

Ukraine

Armenia

UAE

Dubai

Oman

India

Chandigarh

Gurgaon

Kolkata

Ahmedabad

Mumbai

Pune

Hyderabad

Bangalore

Chennai

Coimbatore

Visakhapatnam

Jamshedpur

Myanmar

Thailand

Vietnam

Malaysia

Singapore

Indonesia

Australia

Melbourne

Philippines

China

Shanghai

Wujiang

Taoyuan
(Technology Center & Plant 1)

Zhong Li

Taichung

Tainan

Heilongjiang
Harbin

Jilin
Changchun

Liaoning
Shenyang
Dalian

Shanxi
Taiyuan

Beijing

Tianjin

Hebei
Shijiazhuang

Shandong
Weifang
Qingdao
Jinan
Linyi

Jiangsu
Yangzhou
Nanjing
Nantong
Changzhou
Wuxi
Suzhou
Zhangjiagang

Shanghai

Anhui
Hefei

Zhejiang
Hangzhou
Ningbo
Taizhou
Wenzhou
Jiaxing
Shaoxing

Fujian
Xiamen

Jiangxi
Nanchang

Guangdong
Shantou
Dongguan
Shenzhen
Guangzhou
Foshan

Guangxi
Nanning

Yunnan
Kunming

Sichuan
Chengdu

Shaanxi
Xian

Henan
Zhengzhou

Hubei
Wuhan

Hunan
Changsha

Chongqing

New Zealand



Smarter. Greener. Together.

Industrial Automation Headquarters

Delta Electronics, Inc.

Taoyuan Technology Center
No.18, Xinglong Rd., Taoyuan District,
Taoyuan City 33068, Taiwan
TEL: 886-3-362-6301 / FAX: 886-3-371-6301

Asia

Delta Electronics (Shanghai) Co., Ltd.

No.182 Minyu Rd., Pudong Shanghai, P.R.C.
Post code : 201209
TEL: 86-21-6872-3988 / FAX: 86-21-6872-3996
Customer Service: 400-820-9595

Delta Electronics (Japan), Inc.

Tokyo Office
Industrial Automation Sales Department
2-1-14 Shibadaimon, Minato-ku
Tokyo, Japan 105-0012
TEL: 81-3-5733-1155 / FAX: 81-3-5733-1255

Delta Electronics (Korea), Inc.

Seoul Office
1511, 219, Gasan Digital 1-Ro., Geumcheon-gu,
Seoul, 08501 South Korea
TEL: 82-2-515-5305 / FAX: 82-2-515-5302

Delta Energy Systems (Singapore) Pte Ltd.

4 Kaki Bukit Avenue 1, #05-04, Singapore 417939
TEL: 65-6747-5155 / FAX: 65-6744-9228

Delta Electronics (India) Pvt. Ltd.

Plot No.43, Sector 35, HSIIDC Gurgaon,
PIN 122001, Haryana, India
TEL: 91-124-4874900 / FAX : 91-124-4874945

Delta Electronics (Thailand) PCL.

909 Soi 9, Moo 4, Bangpoo Industrial Estate (E.P.Z),
Pattana 1 Rd., T.Phraksa, A.Muang,
Samutprakarn 10280, Thailand
TEL: 66-2709-2800 / FAX : 662-709-2827

Delta Energy Systems (Australia) Pty Ltd.

Unit 20-21/45 Normanby Rd., Notting Hill Vic 3168, Australia
TEL: 61-3-9543-3720

Americas

Delta Electronics (Americas) Ltd.

Raleigh Office
P.O. Box 12173, 5101 Davis Drive,
Research Triangle Park, NC 27709, U.S.A.
TEL: 1-919-767-3813 / FAX: 1-919-767-3969

Delta Greentech (Brasil) S/A

São Paulo Office
Rua Itapeva, 26 – 3º Andar - Bela Vista
CEP: 01332-000 – São Paulo – SP - Brasil
TEL: 55-11-3530-8642 / 55-11-3530-8640

Delta Electronics International Mexico S.A. de C.V.

Mexico Office
Vía Dr. Gustavo Baz No. 2160, Colonia La Loma,
54060 Tlalnepantla Estado de Mexico
TEL: 52-55-2628-3015 #3050/3052

EMEA

Headquarters: Delta Electronics (Netherlands) B.V.

Sales: Sales.IA.EMEA@deltaww.com
Marketing: Marketing.IA.EMEA@deltaww.com
Technical Support: iatechnicalsupport@deltaww.com
Customer Support: Customer-Support@deltaww.com
Service: Service.IA.emea@deltaww.com
TEL: +31(0)40 800 3800

BENELUX: Delta Electronics (Netherlands) B.V.

De Witbogt 20, 5652 AG Eindhoven, The Netherlands
Mail: Sales.IA.Benelux@deltaww.com
TEL: +31(0)40 800 3800

DACH: Delta Electronics (Netherlands) B.V.

Coesterweg 45, D-59494 Soest, Germany
Mail: Sales.IA.DACH@deltaww.com
TEL: +49(0)2921 987 0

France: Delta Electronics (France) S.A.

ZI du bois Challand 2, 15 rue des Pyrénées,
Lisses, 91090 Evry Cedex, France
Mail: Sales.IA.FR@deltaww.com
TEL: +33(0)1 69 77 82 60

Iberia: Delta Electronics Solutions (Spain) S.L.U

Ctra. De Villaverde a Vallecas, 265 1º Dcha Ed.
Hormigueras – P.I. de Vallecas 28031 Madrid
TEL: +34(0)91 223 74 20

Carrer Llacuna 166, 08018 Barcelona, Spain

Mail: Sales.IA.Iberia@deltaww.com

Italy: Delta Electronics (Italy) S.r.l.

Ufficio di Milano Via Senigallia 18/2 20161 Milano (MI)
Piazza Grazioli 18 00186 Roma Italy
Mail: Sales.IA.Italy@deltaww.com
TEL: +39 02 64672538

Russia: Delta Energy System LLC

Vereyskaya Plaza II, office 112 Vereyskaya str.
17 121357 Moscow Russia
Mail: Sales.IA.RU@deltaww.com
TEL: +7 495 644 3240

Turkey: Delta Greentech Elektronik San. Ltd. Sti. (Turkey)

Şerifaii Mah. Hendem Cad. Kule Sok. No:16-A
34775 Ümraniye – İstanbul
Mail: Sales.IA.Turkey@deltaww.com
TEL: + 90 216 499 9910

GCC: Delta Energy Systems AG (Dubai BR)

P.O. Box 185668, Gate 7, 3rd Floor, Hamarain Centre
Dubai, United Arab Emirates
Mail: Sales.IA.MEA@deltaww.com
TEL: +971(0)4 2690148

Egypt + North Africa: Delta Electronics

511 Cairo Business Plaza, North 90 street,
New Cairo, Cairo, Egypt
Mail: Sales.IA.MEA@deltaww.com